

# RespirAide

LIFE IS HARD *Breathe Easy*

## RespirAide R400T

### ELECTRONIC AIR PURIFIER



OPERATIONAL MANUAL  
Model No. R400T



**WARNING:**

- *This unit cannot be used in an atmosphere containing explosive dust, gas or oxygen, or in an area where flammable dust is present.*
- *This product can be used only where the power supply is 120V/60Hz. You cannot use the unit if the power voltage is different.*

**Platinum Air Care**  
*world leaders in home filtration technology*

410 Third St. London, Ontario  
Canada N5W 4W6  
Tel: (519) 686-3595  
Fax: 1-877-339-4701  
[www.platinumaircare.ca](http://www.platinumaircare.ca)



## **RespirAide 400T Warranty**

Your Electronic Air Cleaner is guaranteed by Platinum Air Care for two (2) full years from the date of original purchase, against all factory defects; including, any electrical and any mechanical defects in material and workmanship, under normal use and maintenance. Warranty items will be repaired or replaced without charge, upon inspection by our authorized service center at Platinum Air Care. The warranty does not include the Pre-filter, UV Light or Odor & Gas (VOC) Filter.

Your **Electronic Collecting Cell** is guaranteed by Platinum Air Care for **twenty-five (25) full years** from the date of original purchase, against all factory defects; including any electrical or mechanical defects in material and workmanship, under normal use and maintenance, and will be repaired or replaced without charge, upon inspection by an authorized service center. This warranty does not include the ionizing wires (located on the Collecting Cell) or damage to fins caused from improper cleaning or obvious abuse.

This guarantee is in lieu of any other warranty, either expressed or implied.

**Platinum Air Care** will not be responsible for:

1. Normal maintenance including cleaning or replacement of filters and UV Lights as outlined in the Owner's Manual.
2. Damage or repairs needed as a consequence of any misuse, negligent handling, **use of non-warranty approved cell cleaners and cleaning products**, improper servicing, unauthorized alteration, improper operations or use on voltage other than that stamped on the Air Cleaner.
3. Any personal injury, property damage, or any incidental or consequential damages of any kind, resulting from defects, malfunctions, misuse, or alteration of the product.
4. Damage as a result of floods, winds, fires, lightning, accidents, corrosive atmosphere, or other conditions beyond the control of Platinum Air Care.
5. Cell cleaners, parts, filters or servicing not warranty approved, supplied or performed by Platinum Air Care.

It is the customer's responsibility to return the unit to the Platinum Air Care Service warranty department. A service call charge will be charged, to the client, for pick-ups or deliveries of warranty items.

If warranty service is required, contact the Service Department of **Platinum Air Care** at:

**Local: (519) 686-3595    Toll Free: 1 (877) 339-4701**

**Email: [Service@platinumaircare.ca](mailto:Service@platinumaircare.ca)**

Nick Dereza  
President, Platinum Air Care

## TABLE OF CONTENTS

<b>FOR CUSTOMER ASSISTANCE</b>	E-4
<b>CONSUMER LIMITED WARRANTY</b>	E-5
<b>CHAPTER 1</b> IMPORTANT SAFETY PRECAUTIONS	E-6~10
<b>CHAPTER 2</b> HOW IT WORKS	E-11
<b>CHAPTER 3</b> PART NUMBER AND NAME	E-12
Part Numbers	E-12
Part Names	E-12
<b>CHAPTER 4</b> FEATURES AND SPECIFICATIONS	E-13
Features	E-13
Product Specifications	E-13
<b>CHAPTER 5</b> OPERATION	E-14
Main Unit Operation	E-14
Setting New Functions	E-15
Remote Control Operation	E-16
<b>CHAPTER 6</b> CARE AND MAINTENANCE	E-17
Cleaning the Pre-filter	E-17
Cleaning the Electronic Cell	E-18
Replacing the Activated Carbon Filter	E-19
Photo catalytic Filter and UV Lamps	E-19
<b>CHAPTER 7</b> FREQUENTLY ASKED QUESTIONS (FAQs)	E-20
Why Does My Air Purifier Spark?	E-20
How Should I Clean the Cell ?	E-20
How Often Should I Change the Activated Carbon Filter (Charcoal Filter)?	E-20
<b>CHAPTER 8</b> TROUBLESHOOTING	E-21
The unit does not operate	
When functions do not work	
Automatic Function Does not Work Properly	
When Other Problems in Terms of Functions Are Found	
<b>CHAPTER 9</b> ELECTRICAL WIRING DIAGRAM	E-22
<b>SERVICE REMINDER SCHEDULE</b>	E-23

## FOR CUSTOMER ASSISTANCE

Platinum Air Care  
410 Third St.  
London, Ontario Canada  
N5W 4W6

Tel: (519) 686-3595  
Fax: 1-877-339-4701

If you have any questions about your air purifier, call the customer service number. Before calling, please note the model and serial number located on the back of the unit and fill in the following information below. This information will help us answer your questions much more quickly.

**Model number**

---

**Serial number**

---

**Date of purchase**

---

**Dealer name**

---

**Address**

---

**City**

---

**Province**

---

**Postal code**

---

**Telephone**

---

Phone: 1-877-339-4701

Write: For service problems, guarantee information, missing items and other assistance:

Platinum Air Care  
410 Third St. London, Ontario Canada  
N5W 4W6

Please provide the following information when you write or call: model number, serial number, date of purchase, your complete mailing address (including Postal Code), your daytime telephone number (including area code) and description of the problem.

## CONSUMER LIMITED WARRANTY

### RESPIRAIDE ELECTRONIC AIR PURIFIER

#### LIMITED WARRANTY

*Congratulations on your investment*

RespirAide Tech Inc. (Hereinafter called RTI) gives you the following limited warranty for this product only if it was originally purchased from RTI or from an Authorized RTI Dealer.

RTI warrants that this product is free, under normal use and maintenance, from any defects in material and workmanship. If any such defects should be found in this product within the applicable warranty period. RTI shall, at its option, repair or replace the product as specified herein.

RTI will repair or replace, free of charge, to the original purchaser, any part that is found to be defective in material or workmanship within one (1) year of the date of purchase. This limited warranty does not cover the replacement of expendable or consumable parts such as filters, and other parts subject to normal wear unless they are defective in material or workmanship.

#### ***This warranty shall not apply if:***

- Any defects caused or repairs required because of abusive operation, negligence, accident, improper installation or inappropriate use as outlined in the operation manual.
- Any product tampered with modified, adjusted or repaired by any party other than RTI, RTI Authorized Service Centers or RTI Authorized Service Dealers.
- Damage caused or repairs required because of the use with items not specified or approved by RTI.
- Any damage caused by external or environmental conditions, including but not limited to the use of voltage other than indicated on the product.

RTI's limited warranty is valid only if you retain proof of purchase from RTI or a RTI Authorized Retail Dealer for this product.

To obtain to set up inspection of the unit contact  
Authorized RespirAide Dealer, Platinum Air Care at  
410 Third St. London, Ontario, Canada. N5W 4W6  
(519) 686-3595

For more information on this Warranty, or Service  
Locations, please call 1-877-339-4701 or  
Visit our website: [www.platinumaircare.ca](http://www.platinumaircare.ca)

## CHAPTER 1

### IMPORTANT SAFETY PRECAUTIONS

#### Power Cord

#### Unit Operation

TO REDUCE THE RISK OF ELECTRICAL SHOCK, FIRE OR INJURY TO PERSON(S) READ THE FOLLOWING:

- Use only as described in this manual.
  - Use only a 120-volt outlet with grounding wire receptacle.
  - Do not use the air purifier if the power cord or plug is damaged or the connection to the wall outlet is loose.
  - When removing the power plug, always hold the plug and never pull by the cord.
  - Do not handle plug or appliance with wet hands. **Electrical shock or fire from short circuit may occur.**
  - Remove the power plug from the wall outlet before cleaning the unit and when not using the unit. Turn off all controls before unplugging.
  - If the power cord is damaged, it must be replaced by the RespirAide authorized service or similarly qualified person.
  - To reduce the risk of electric shock, this equipment has a grounding type plug that has a third (grounding) pin. This plug will only fit into a grounding type power outlet. If the plug does not fit into the outlet, contact qualified personnel to install the proper outlet. Do not alter the plug in any way.
- 
- **Do not use the unit in an enclosed space where oxygen, flammable, explosive or toxic vapors are given off by oil base paint, paint thinner, some mothproofing substances, or in an area where flammable dust is present.**
  - Do not clean outside with paint thinner or any chemicals. If so, the unit surface may become damaged or may cause fire.
  - Do not wash or reuse the activated carbon filter.
  - Do not operate the unit without filters.
- 
- Do not insert fingers or foreign objects into the intake or air outlet.
  - Keep hair, loose clothing, fingers and all parts of body away from openings and moving parts.
  - Do not block the intake and air outlet.
  - Do not use the unit near or on hot objects, such as range or where it may be exposed to steam.
  - Always hold the handles on the side of the unit when moving it. Holding the front panel when carrying may cause it to detach, and result in bodily harm.
  - Be careful not to tip over the unit when opening the front panel. If not, it may cause bodily harm.
- 
- The batteries must be removed from the remote control before disposal, and the batteries must be disposed of safely.

## CHAPTER 1

### IMPORTANT SAFETY PRECAUTIONS

#### WARNING

If you do not follow these instructions exactly, the unit may cause property damage, personal injury or loss of life.

#### **WARNING:**

- Do not use the unit in the places containing explosive dust, gas or flammable substances.
- Do not cleanse the unit or any parts with flammable substances.
- Do not wash or reuse the activated carbon filter.

This manual classifies precautions into WARNINGS and CAUTIONS. Be sure to follow all precautions below: They are important for ensuring your safety.

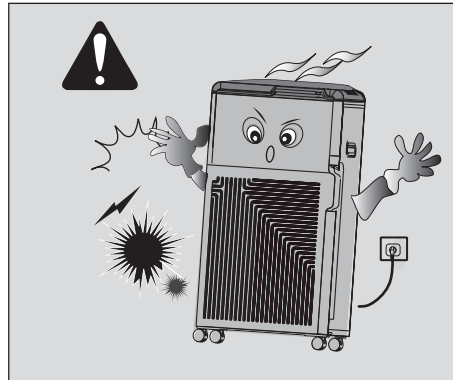

1. This unit cannot be used in an atmosphere containing explosive dust, gas or in an area where flammable substances are present. If so, it results in explosion or fire!

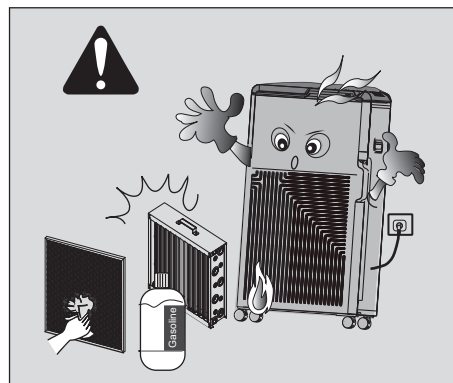

2. Do not clean the unit or any parts (e.g. pre-filter, electronic cell or activated carbon filter etc.) with alcohol, gasoline, paint thinner or other flammable substances.

**It may cause fire!**

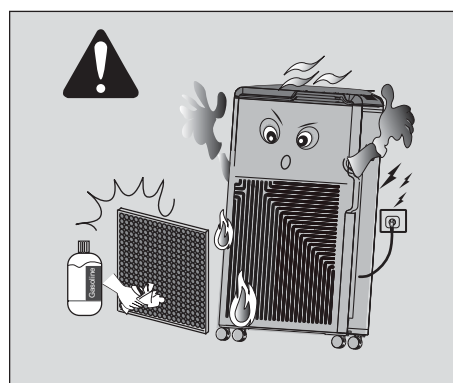

3. Do not wash or reuse the activated carbon filter or clean the activated carbon filter with liquid, especially alcohol, gasoline, paint thinner, etc.. **It may cause fire!**

## CHAPTER 1

### IMPORTANT SAFETY PRECAUTIONS

#### WARNING

If you do not follow these instructions exactly, the unit may cause property damage, personal injury or loss of life.

#### **WARNING:**

- Do not try to place the activated carbon filter in front of the cell.
- Dry the cell and Pre filter thoroughly after cleaning.
- Do not disassemble or modify the unit.

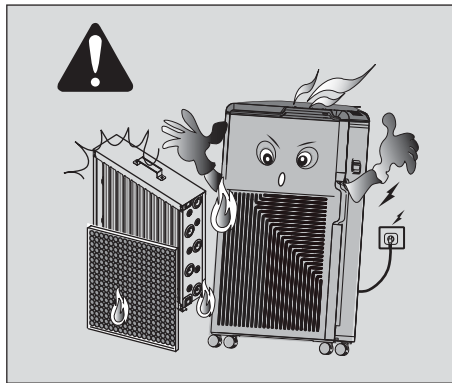

4. The activated carbon filter must be located behind the cell. Do not try to place the activated carbon filter in front of the cell. **It may cause fire!**

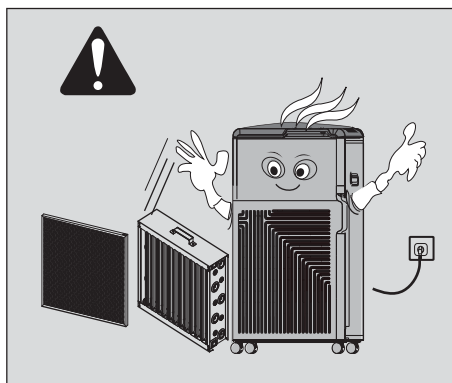

5. After cleaning the filters, make sure to dry them thoroughly before reinstalling. **Failure to do so may cause the unit to stop working or personal injury.**

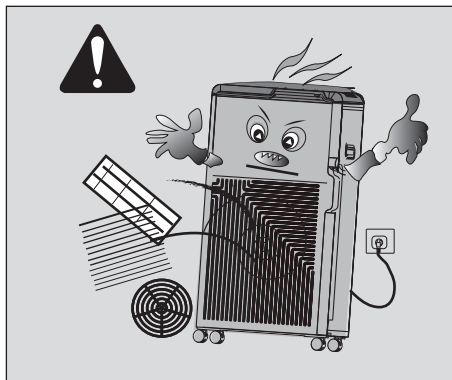

6. Do not disassemble or modify this equipment. Unwarranted tampering can lead to fire, electric shock and unit malfunction.



## CHAPTER 1

### IMPORTANT SAFETY PRECAUTIONS



#### WARNING

If you do not follow these instructions exactly, the unit may cause property damage, personal injury or loss of life.

#### WARNING:

- Do not use the unit in humid places that might be wet.
- Do not place the product in direct contact with sunlight.

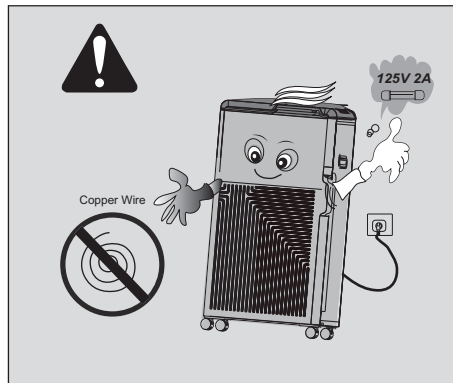

7. Use a fuse with proper capacity. Never use a wire in place of a fuse. Doing this may lead to malfunction or fire.

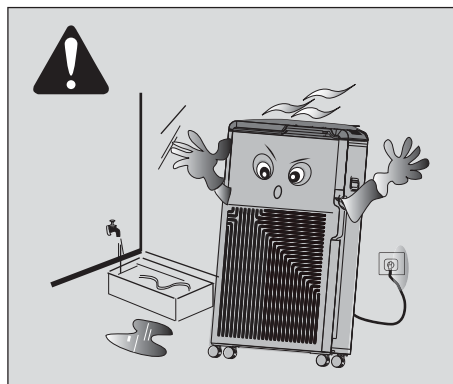

8. Do not use the unit in humid places that might be wet. Contact with water can lead to electric shock or damage the equipment.

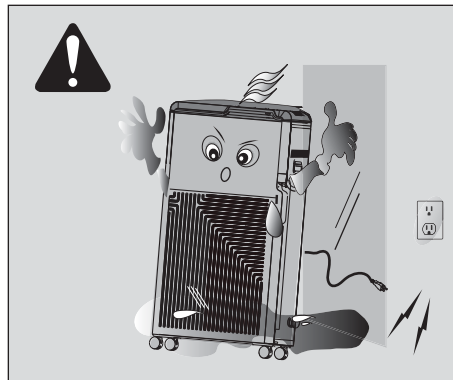

9. If any parts of the power source get wet remove the plug and dry them completely before reusing.

## CHAPTER 1

### IMPORTANT SAFETY PRECAUTIONS



#### CAUTION

If you do not follow these instructions exactly, the unit may cause minor property damage or personal injury.

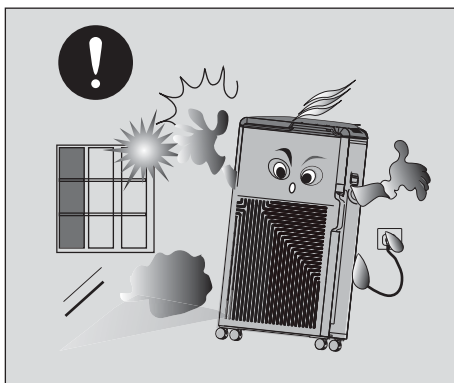

1. Do not place the product in direct contact with sunlight. It may cause malfunction and deformation of the product.

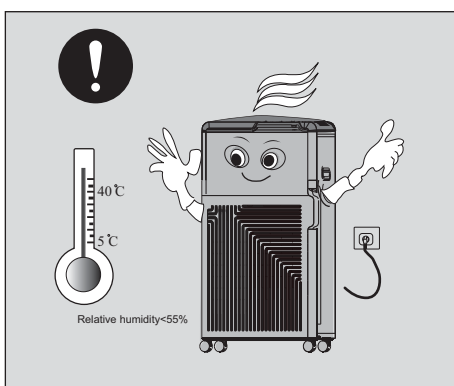

2. Do not use the unit in high humidity conditions. Use the product in the ambient temperature of 0-40°C.

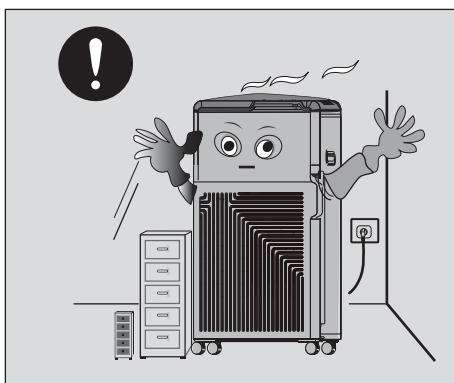

3. Do not block the intake or outlet. Blocked openings can reduce capacity or damage the unit.

## CHAPTER 2

### HOW IT WORKS

#### The air is cleansed in six stages

#### Part Name

- Stage 1 Pre-filter
- Stage 2 Electronic Cell
- Stage 3 Activated Carbon Filter
- Stage 4 UV-C Germicidal Lamp
- Stage 5 Photo catalyst
- Stage 6 Negative Ion Generator

The air purifier functions as an air cleaner by helping to disinfect airborne microorganisms and removing particulates from the air. The centrifugal fans of the unit draw air through the front panel (Intake) on the front of the unit. Then it passes through the Pre-filter, the electronic cell, the activated carbon filter and the UV-Photo catalytic sterilization chamber. The purified air is then released through the outlet on the top of the unit.

#### The air is cleansed in six stages:

- The Pre-filter traps large dust particles.
- The two-stage electrostatic precipitator captures airborne particles. In the ionizing section of the electronic cell, billions of microscopic particles become electrically charged as they pass through the powerful electric field. The collector plates immediately attract and collect these charged dust and dirt particles.
- The activated carbon filter adsorbs and reduces odors, chemicals and gases, removes tobacco smoke, the smell of food and other odors.
- The UV sterilization chamber kills bacteria and viral microorganisms such as influenza, TB and Legionnaire's Disease as well as other harmful contaminants.
- When UV light hits the photo catalytic filter, it creates e- and h+, which have an excellent effect in the decomposition of odors.
- The unit also generates negative ions that freshens the room air.

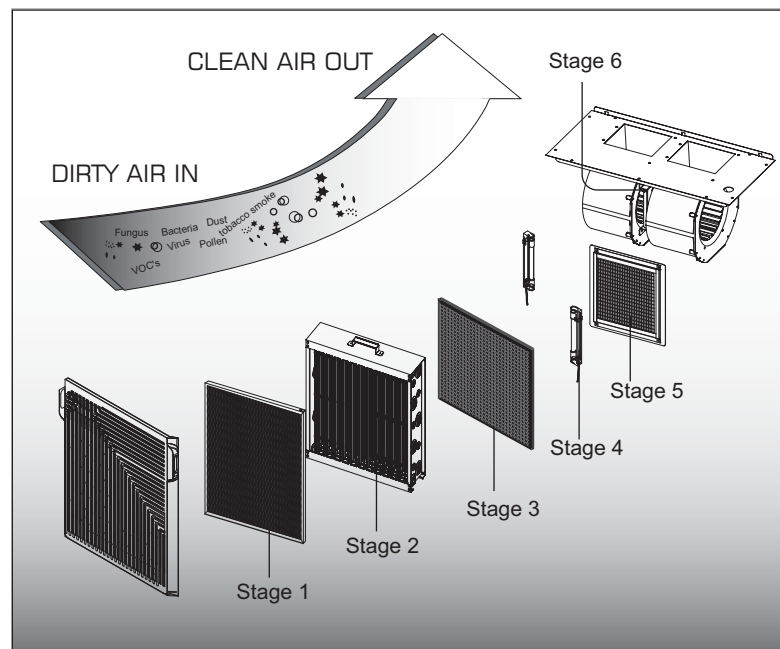

# CHAPTER 3

PART NUMBER  
AND NAME

## Part Numbers

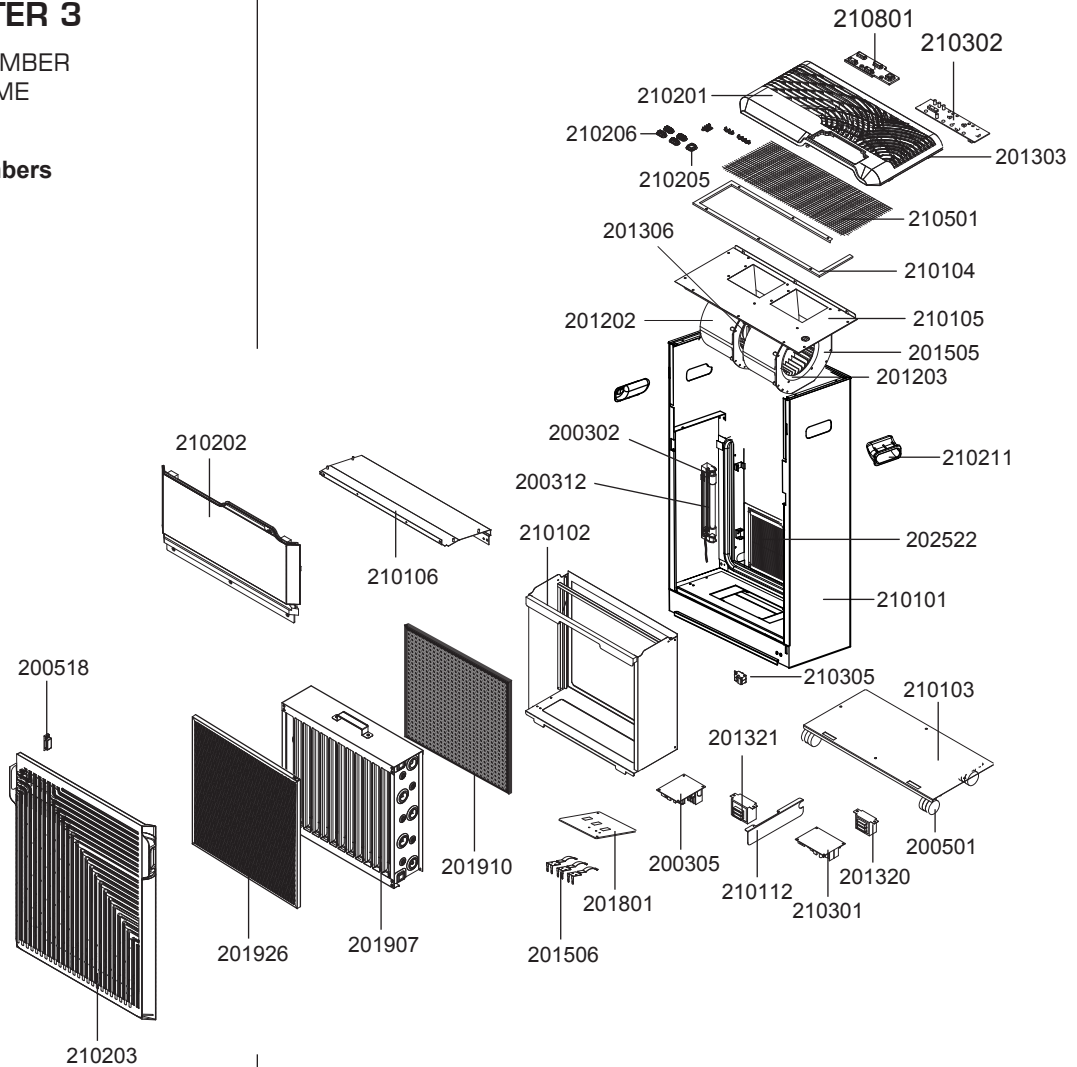

## Part Names

- |                                       |                                 |
|---------------------------------------|---------------------------------|
| 210203 Plastic front panel            | 210101 Unit housing             |
| 200518 Front panel magnet             | 200312 UV lamp                  |
| 210191 Pre-filter                     | 200302 UV lamp holder & ballast |
| 210197 Electronic cell                | 202522 Photo catalyst           |
| 210190 Activated carbon filter        | 210211 Unit Handle              |
| 210102 Filter case                    | 21306 Fan Motor                 |
| 210202 Upper panel                    | 21202 Fan housing               |
| 210106 Fan motor bottom plate         | 21203 Fan blade                 |
| 210506 Unit power contact plate       | 210505 Fan motor side plate     |
| 2101801 Unit epoxy resin board        | 210105 Fan motor top plate      |
| 200305 Power supply                   | 210104 Outlet screen holder     |
| 210309 Power supply transformer       | 210501 Outlet screen            |
| 210112 Circuit board protector        | 210201 Plastic top cover        |
| 210301 Main circuit board             | 210302 Display circuit board    |
| 210308 Main circuit board transformer | 210303 Odor sensor              |
| 200501 Caster                         | 210801 Silica gel button lining |
| 210103 Bottom plate                   | 210205 Power button-square type |
| 210305 Interlock switch               | 210206 Button-rectangle type    |

## CHAPTER 4

### FEATURES AND SPECIFICATIONS

#### Features

#### Product Specifications

#### Multi-Stage Filters

The unit utilizes a two-stage electrostatic precipitator (Electronic cell) combined with a Pre-filter (For large particles), an Activated carbon filter (For odors and gases), UV germicidal light (Killing airborne pathogen), a Photo catalytic filter (Removes VOC's) and a Negative ion generator.

#### Automatic Function

The odor sensor automatically selects the appropriate fan speed depending on the air quality detected.

#### Carbon Filter, UV Lamps Replacement and Cell Cleaning Indicator Lights

The REPLACE CARBON FILTER, REPLACE UV LAMPS indicator lights tell you when to replace the activated carbon filter or the UV lamps. Also, the CLEAN CELL indicator light tells you when to clean the electronic cell.

#### Safety Micro-Switch (Interlock switch)

This air purifier is equipped with a safety interlock switch (Micro-safety switch) that will turn the unit off if the front panel is opened while the unit is running.

#### Easy Maintenance and Low Cost

When the electronic cell needs to be washed or the filters need to be replaced, simply open the front panel and pull out the electronic cell or old filters and put the new or clean one in.

No screws, hooks or tools are required. The electronic cell captures small particles on aluminum plates that are simply rinsed off in the sink.

#### Specifications

Model No.	R400T (RespirAide 400T)
Power Requirement	120V, 60Hz, 1A
Rated Power	96W
Fan Motor	120V, 60Hz
Noise Level	<55dB
Negative Ion	$3 \times 10^6 / \text{cm}^3$
UV Lamp	6Wx2
Dimensions	H83.5cmxW47.8cmxD23.8cm
Weight	23.8kg

#### Standby Power

In order to operate the electrical circuits while the power plug is inserted in the wall outlet, this product consumes about 5.8W of standby power. For energy conservation, unplug the power cord when the unit is not in use.

## CHAPTER 5

### OPERATION

#### POWER Button:

- When the power cord is connected to the electrical outlet, the indicator light will light up yellow and pressing the POWER button to start the unit and it will turn white in color.
- Hold the Power button down 3 seconds to RESET the indicator lights after *CLEANING CELL*, *REPLACING THE CARBON FILTER* and *THE UV LAMPS*.

#### AUTO Mode:

Every time the power plug is inserted into the wall outlet, the auto sensor needs a short warming up period. During this time, the SPEED indicator lights flash, moving from L to H.

### Main Unit Operation

#### Connect the Power

Plug the unit into an electric outlet, the unit will be ready to run and all the indicators on the display panel will light up for 2 seconds.

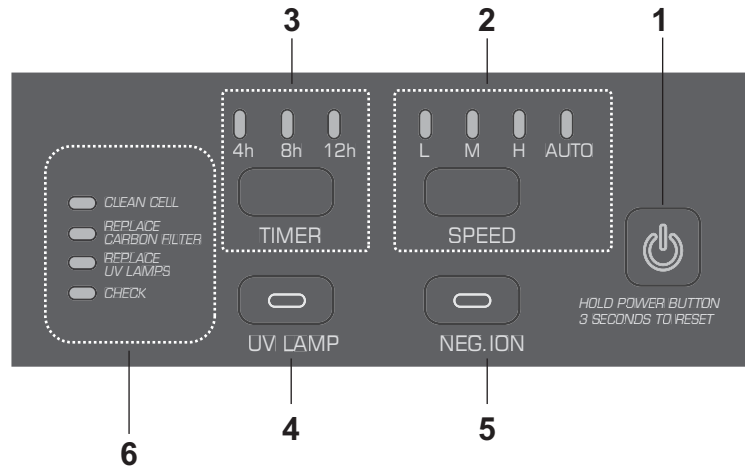

#### 1. POWER Button

Press the POWER button to start the unit, re-press it to stop. The unit will run at low speed when the POWER button is pressed.

#### 2. SPEED Button

When the power is on, the unit will be set at the L speed and the indicator lights will illuminate, select the speed by pressing the SPEED button. Each time the SPEED button is pressed the airflow rate changes as shown below:

L ----- M ----- H ----- AUTO ----- L...

#### 3. TIMER Button

When the TIMER button is pressed, the indicator light will light up. The indicator light shows the set time. Press the TIMER button to select the time for operation. The unit will automatically turn off once the timer has counted down to zero.

#### 4. UV LAMP Button

When the UV LAMP button is pressed, it will turn off the UV lamps, pressing again will turn on the UV lights. The indicator light will light up when the UV lights are on.

#### 5. NEG.ION Button

When pressed, the generation of ions will cease and the negative ion generator light on the button will go out.

#### 6. INDICATOR Lights

- **CLEAN CELL indicator light**- When the *CLEAN CELL* indicator light flashes, the cell needs to be washed.
- **REPLACE CARBON FILTER indicator light**  
When the *REPLACE CARBON FILTER* indicator light flashes, the activated carbon filter needs to be replaced.
- **UV LAMP indicator light**  
If the *REPLACE UV LAMPS* flashes, it tells the time for the UV lamps to be replaced.
- **CHECK indicator light**  
When the indicator light flashes red with beeping, please contact customer service.

## CHAPTER 5

### OPERATION

#### Setting new functions

**Note:** This function is helpful for drying the cell thoroughly after cleaning.

#### Setting New Functions

The unit buttons offers access to a number of functions:

##### 1. Timer Cycle Function

Step1. Power off the unit.

Step2. Hold the TIMER button for 3 seconds until the "8 hour" indicator light comes on.

Step3. Press the TIMER button one time and wait for all the timer lights flash.

Step4. Press the POWER button

Step5. Press the POWER button to operate the unit.

Step6. Press the TIMER button again. This time all the indicator lights will be on.

In this case the unit will start to work 2 hours and stops 2 hours automatically

If you want to return to the default mode, do the reverse.

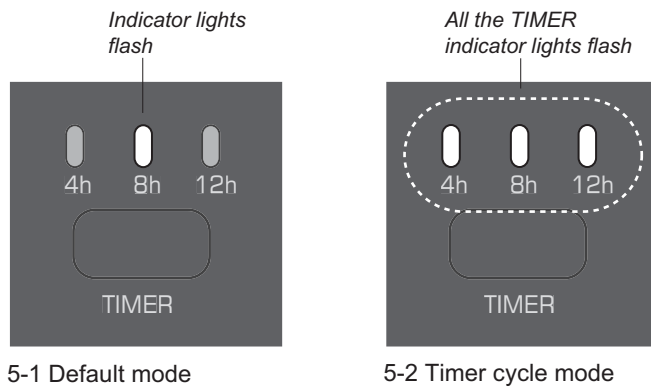

##### 2. Cell Clean Dry Function

- Stop the unit operation and hold down the SPEED button until you hear a beep sound to set up the Cell Clean Dry function mode.
- In this mode, the unit electronic cell does not charge for 45 minutes allowing time to dry the cell.
- After running 45 minutes, the cell will automatically charge and start to work.

##### 3. Change the Button Melody

- Stop the unit operation and hold down the UV LAMP and NEG. ION buttons at the same time until you hear the new melody.
- If you want to go back to the default melody, do the reverse.

## CHAPTER 5

### OPERATION

#### Remote Control Operation

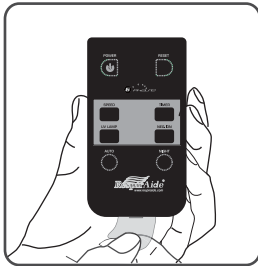

Pull out the clear sheet from the battery cover before using.

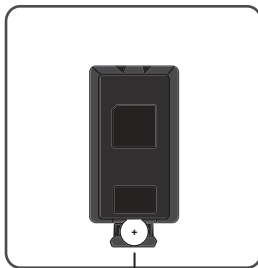

CR2025 Battery

#### Battery Information

- Open the cover on the rear of the remote control towards the arrow.
- Replace the battery with CR2025 battery. Be sure to set the battery with the (+) side up.
- Close the cover to its original position.
- The battery for this remote control is for initial use only. Change the battery when necessary.
- When not using the unit or remote control for an extended period, remove the battery.

#### Remote Control Operation

The battery is already set in the remote control, pull out the clear sheet from the battery cover before using.

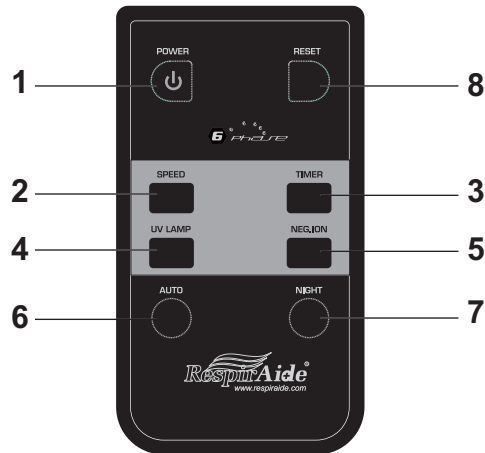

#### 1. POWER Button

The unit will start operating when the POWER button is pressed. Pressing the button again will stop operation.

#### 2. SPEED Button

The fan speed can be switched among Low, Medium and High settings.

#### 3. TIMER Button

The set time switches every time when the button is pressed as shown below:

*L ----- M ----- H ----- AUTO ----- L...*

#### 4. UV LAMP Button

When pressed, turn off the UV lamp.

#### 5. NEG.ION Button

When pressed, the generation of ions will cease and the negative ion generator light on the control panel will go out.

#### 6. AUTO Button

In Auto mode, the fan speed is automatically switched (L and M) depending on the amount of pollution in the air.

#### 7. NIGHT Button

When pressed, all the indicators will go out except the POWER button light on the control panel.

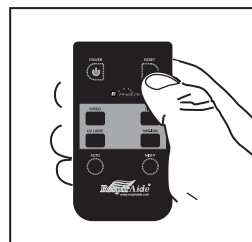

#### 8. RESET Button

After the replacement of activated carbon filter or the UV lamp, make sure to press RESET button 3 times to reset the timer. After cleaning the electronic cell, press the RESET button 3 times to reset the cell cleaning time.

**Note:** Before pressing the RESET button, be sure the unit is plugged in.



## CHAPTER 6

### CARE AND MAINTENANCE

#### **WARNING:**

*Cleaning the unit while it is plugged in may result in electric shock, electric spark and serious injury. Unplug the unit before cleaning or maintenance!*

#### Cleaning the Pre-filter

#### **WARNING:**

- *DO NOT clean the Pre-filter with flammable substances (Alcohol, gasoline, paint thinner, etc.). It may cause fire!*
- *After cleaning the Pre-filter, it is very important to dry it completely before placing it back in the unit.*
- *During maintenance, be careful not to tip over the unit. It may cause personal injury.*

To maintain optimum performance of this air purifier, please clean the unit including the Pre-filter and electronic cell periodically.

**When cleaning the unit, be sure to unplug the power cord, and never handle the plug with wet hands. If so, electrical shock and bodily injury may occur as a result.**

#### Main Unit

To prevent dirt or stains on the main unit, clean as often as necessary. If stains are allowed to remain, they may become difficult to remove. Wipe with a dry, soft cloth for stubborn stains or dirt, use a soft cloth dampened with warm water. Do not use **volatile fluids, Benzene, paint thinner, polishing powder**, this may damage the surface. Do not use detergents, detergent ingredients may damage the unit. Keep the unit away from water.

#### Cleaning the Pre-filter

To assure optimum performance the Pre-filter should be cleaned regularly-every one to two weeks. Washing frequency will vary depending on the number of family members, pets, activities (such as cooking or woodworking) and smoking habits. Use the wash reminder schedule in this manual.

- **Stop the operation and unplug the unit.**
- Open the front panel.
- Pull the Pre-filter straight up and out of the front panel.
- After using a vacuum cleaner to remove any dust, clean with water. If it is very dirty, use a soft brush or a neutral cleaner to clean then dry completely before placing it back into the unit.
- Place the Pre-filter back into the front panel by sliding straight down into the slots.



6-1 Open the front panel



6-2 Removing the Pre-filter

## CHAPTER 6

### CARE AND MAINTENANCE

#### **WARNING:**

- **DO NOT** clean the cell with alcohol, gasoline, paint thinner or other flammable substances. It may cause fire!
- **DO NOT** reinstall the cell until it is completely dry. If the **CHECK** light flashes red, then the cell may still be wet.
- Be sure there is no detergent residue around the cell ceramic insulators, especially around the square shape ceramic insulators.
- Slide in the cell so the airflow arrow points toward the machine.



Reset the **CLEAN CELL** indicator light

- Hold the **POWER** button down on the control panel 3 seconds to reset the **CLEAN CELL** indicator light.

## Cleaning the Electronic Cell

### **Remove the electronic cell**

- **Stop the operation and unplug the unit.**
- Please wait **5-10** seconds before taking off the front panel.
- Pull the cell straight up and out of the filter cabinet.



6-3 Open the front panel



6-4 Removing the cell

- If the **CLEAN CELL** indicator lights flashes, it is the time to clean the cell.
- If the air quality is extremely poor and the cell is dirty, you may clean the cell before **CLEAN CELL** indicator light flashes.

### **How to clean the electronic cell**

- To assure optimum performance the cell should be cleaned every one to two months.
- Use a large enough container, such as a laundry tub or trash container. Dissolve detergent in warm water to cover the cell. After the detergent has completely dissolved, place the cell in the container. Allow the cell to soak for 15~30 minutes and rinse with clean water. Tough residue such as tar from tobacco smoke may need longer soaking.
- After cleaning, make sure to rinse detergent residue thoroughly out of the ceramic insulators of the cell. Dry the cell thoroughly with heat gun before reinstalling.

### **Reset the CLEAN CELL indicator light**

After sliding the clean cell in the unit, hold the **POWER** button down on the control panel 3 seconds or press the **RESET** button on the remote control 3 times to reset the **CLEAN CELL** indicator light.

### **Helpful Hints**

The electronic cell stops powering up for 45 minutes every time you clean the cell and reset the **CLEAN CELL** indicator light.

## CHAPTER 6

### CARE AND MAINTENANCE



**Note:**

Remove plastic packaging from the activated carbon filter before operation.

**WARNING:**

- DO NOT reuse or clean the activated carbon filter with liquid, especially alcohol, gasoline, paint thinner, etc. It may cause fire!
- DO NOT try to place the activated carbon filter in front of the cell! It may cause fire!

**WARNING:**

- Never look directly at UV lamp.
- Direct exposure to germicidal light can cause temporary or chronic damage to your eyesight, or even blindness.
- Always unplug the unit before cleaning, servicing or replacing the UV lamp.

### Replacing the Activated Carbon Filter

When the *REPLACE CARBON FILTER* indicator light flashes, the activated carbon filter needs to be replaced.

- **Stop the operation and unplug the unit.**
- Please wait **5-10** seconds before opening the front panel.
- Remove the old activated carbon filter from the filter cabinet and insert a new one.



6-5 Replace the activated carbon filter

If the air quality is extremely poor, you may replace the activated carbon filter before the *REPLACE CARBON FILTER* indicator light flashes. The activated carbon filter is located behind the electronic cell.

### Reset the *REPLACE CARBON FILTER* indicator light

After replacing the activated carbon filter, hold the **POWER** button down on the control panel 3 seconds or press the **RESET** button on the remote control 3 times to reset the indicator light.

### Photo catalytic Filter and UV Lamps

#### Photo catalytic filter

Photo catalytic filter is permanent, never needs replacing. When there is dust on it, clean the dust off using a vacuum cleaner dusting brush. Do not wash it in water.

#### UV lamps

- When the *REPLACE UV LAMPS* indicator light on the control panel flashes, it is time to replace the UV lamps.
- Removing the UV light blocker, gently rotate the lamp a quarter turn in either direction until it unlocks from the socket.



6-6 Replace the UV Lamps

After removing the UV light blocker, rotate the lamp to unlock it from the socket.

## CHAPTER 7

### FREQUENTLY ASKED QUESTIONS (FAQs)

#### Why does my air purifier spark?

It is common for the purifier to spark, crackle or pop during operation. A spark indicates that the air purifier captured a large air particle. If the unit sparks continuously:

- The electronic cell may be excessively dirty or have a foreign object lodged between the plates. Remove the cell from the unit and wash thoroughly.
- Visually inspect the cell for any foreign debris lodged between the plates. Also, inspect for broken ionizing wires, chipped or cracked ceramic insulators, or bent plates.
- When replacing cell in the unit, make sure the directional arrow on the cells point toward the unit.

#### How should I clean the cell?

- Stop the operation and unplug the unit.
- Please wait 5-10 seconds before opening the front panel.
- To assure optimum performance the cell should be cleaned every one to two months.
- Use a large enough container, such as a laundry tub or trash container. Dissolve detergent in warm water to cover the cell. After the detergent has completely dissolved, place the cell in the container. Allow the cell to soak for 15~30 minutes and rinse with clean water. Tough residue such as tar from tobacco smoke may need longer soaking.
- After cleaning, make sure to rinse detergent residue thoroughly out of the ceramic insulators of the cell. Dry the cell thoroughly with heat gun before reinstalling.

#### **Important Note:**

It is very important that the cell is allowed to dry completely before sliding them back into the cell cabinet as electricity is passed through the cell.

#### How often should I change the activated carbon filter (Charcoal filter)?

The function of the activated carbon filter is to adsorb odors and freshen the air. When the *REPLACE CARBON FILTER* indicator light on the control panel flashes, you should replace the activated carbon filter. Even before the indicator light flashes you can replace the activated carbon filter using your best judgment based on the odors you perceive in your home.

**CHAPTER 8**  
TROUBLESHOOTING

Service problems that appear to be major can often be solved easily. You can be your own troubleshooter by reviewing the following guide. All other servicing should be done by a RespirAide authorized service center.

**The unit does not operate**

Power failure?	Check other electrical appliances.
Power plug disconnected?	Make sure to insert the plug.
Is the fuse burnt?	Replace the FUSE with new one.
Front panel open or interlock switch failure?	The unit does not operate when the front panel is detached. Install properly. Check interlock switch.
Is the CHECK light flashing?	The cell may be wet after cleaning. Dry it thoroughly. If not, call the Customer Service.
There is too much dust on the Pre-filter, activated carbon filter?	Clean the filters or replace them.
There is too much dust on the electronic cell?	Wash it and dry completely before reinstalling it.
The air inlet or outlet blocked?	Get rid of foreign materials around the outlets.
There is too much dust on the sensor?	Clean the dust on the sensor.
There is no dust on the sensor.	Call the Customer Service.

**When functions do not work**

**Automatic function does not work properly**

**When other problems in terms of functions are found**

Check the problems first and then unplug the power cord. Call the Customer Service to ask for after-sale service or make inquiries.

# CHAPTER 9

## ELECTRICAL WIRING DIAGRAM

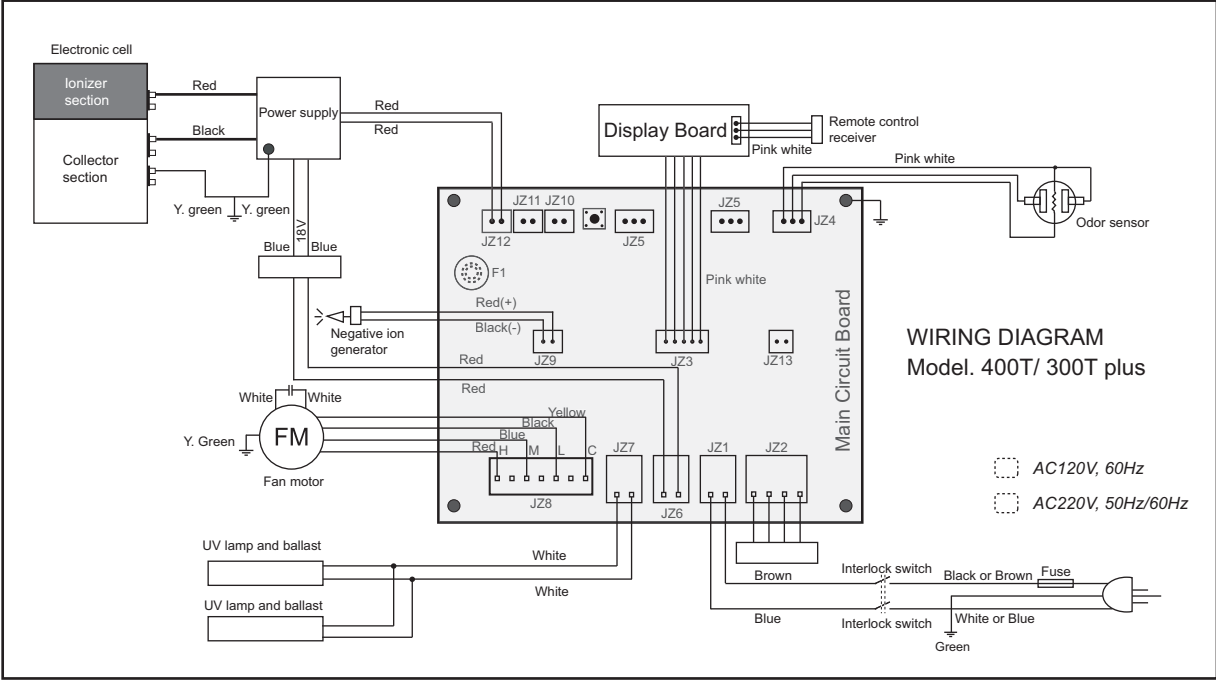

**SERVICE REMINDER  
SCHEDULE**

Pre-filter Wash Reminder

Year	<i>J</i>	<i>F</i>	<i>M</i>	<i>A</i>	<i>M</i>	<i>J</i>	<i>J</i>	<i>A</i>	<i>S</i>	<i>O</i>	<i>N</i>	<i>D</i>

Memo:

Electronic Cell Wash Reminder

Year	<i>J</i>	<i>F</i>	<i>M</i>	<i>A</i>	<i>M</i>	<i>J</i>	<i>J</i>	<i>A</i>	<i>S</i>	<i>O</i>	<i>N</i>	<i>D</i>

Memo:



410 Third St. London, Ontario Canada  
N5W 4W6  
Tel: (519) 686-3595  
Fax: 1-877-339-4701  
Email: [Service@platinumaircare.ca](mailto:Service@platinumaircare.ca)  
[www.platinumaircare.ca](http://www.platinumaircare.ca)

**KEEP YOUR AIR CLEAN  
REPLACE YOUR FILTERS EVERY 3-6 MONTHS**

RespirAide reserves the right to revise or modify products and/or specifications without notice.  
The contents of this manual are subject to change without notice.

Ver. 400T-01